

SWS-02 Installation procedure

Introduction

The aim of this document is to describe the installation procedures applicable to the installation of the SWS-02 strain sensor on a surface of a monitored object.

The document is focused on the spot-welding method which is the primary and recommended method for achieving a long term stable bond between the monitored structure and the SWS-02 sensor.

Other installation possibilities are mentioned in the last chapter.

Installation requirements

Instruments & Tools

- Standard spot welding machine for 0.2mm stainless steel plates. Typically this works well with regular spot welders used for electrical gauges.
- FBG interrogator
- PST-02 Pre-strain set up tool for SWS-02 sensor

Installation time

Typical spot-welded installation time of SWS-02 sensor: **between 5-10min** (surface preparation not taken into account).

Installation sequence

This sequence is described in the next chapters in more detail. Time indicates estimated time efforts.

- (1) Removing transportation protection from the sensor [1 minute]
- (2) Mounting of PST-02 and setting up the desired pre-strain [2 minutes] ¹⁾
- (3) Surface preparation for spot welding [5 minutes] ²⁾
- (4) Spot welding of the sensor to the surface [5 minutes]
- (5) Removing PST-02 from the sensor [2 minutes]

¹⁾ It requires the sensor to be connected to the interrogator.

²⁾ Time for completing highly depends on the surface of the monitored object.

(1) Removing transportation protection from the sensor

SWS-02 comes with a preinstalled Transportation fixture – this is to protect the sensor during transportation and initial manipulation. This transportation fixture needs to be removed from the sensor before installation.

Remove the screws and top plate from SWS-02 as shown in Figure 2 – follow the alphabetical order of all parts as listed in Figure 1. All tools are included inside the PST-02 package.

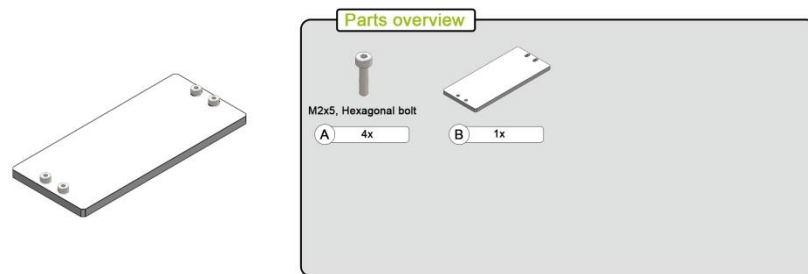

Figure 1: Parts overview of the Transportation fixture.

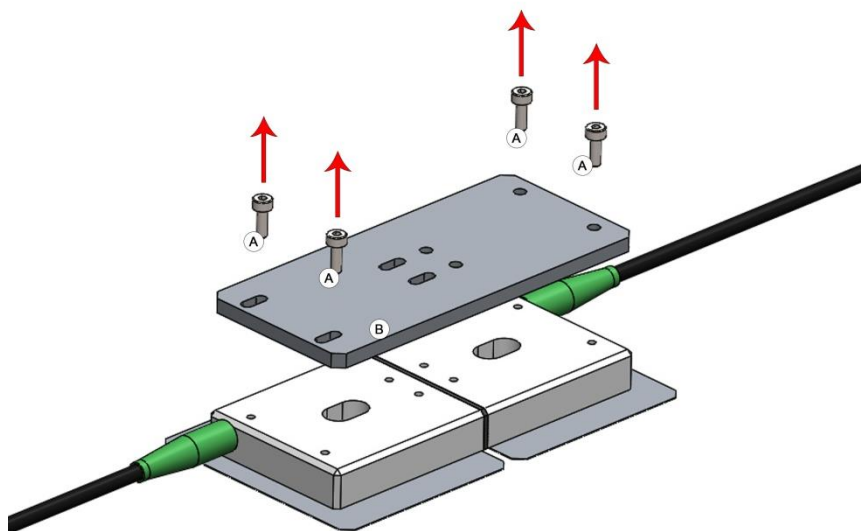

Figure 2: Removing the Transportation fixture.

If you are not installing the sensor, it is recommended to mount the transportation fixture back on the sensor.

(2) Mounting of PST-02 and setting up the desired pre-strain

SWS-02 comes with very small pre-strain not applicable for compression measurement therefore it is necessary to adjust the pre-strain on the SWS-02 before installation. For this purpose, the PST-02 pre-strain setup tool is used. It allows setting the desired pre-strain level to the sensor just before the direct installation of the sensor to the surface and it also keeps the defined pre-strain during installation. After installation, the PST-02 is removed from the sensor and can be used for another SWS-02 installation.

- ▲ PST-02 provides safely pre-straining the SWS-02 sensor up to 4000µε.
- ▲ Easy to assembly or disassembly within a fragment of time.

Mounting the PST-02 to the SWS-02 sensor

Mount the PST-02 on the SWS-02 sensor as shown in Figure 4 – follow the alphabetical order of all parts listed in “Parts overview” (Figure 3). All tools are included inside the PST-02 package.

Applying pre-strain to the SWS-02

To apply pre-strain, connect the sensor to an interrogation unit and focus on the higher wavelength. In a standard case, the higher wavelength the for strain measurement and the lower for temperature compensation. Use the knob on the top of the PST-02 (Figure 4) and rotate it clockwise to increase the pre-strain¹ and anti-clockwise to reduce it.

¹It can take several rotations before the sensor will react to the pre-strain tool.

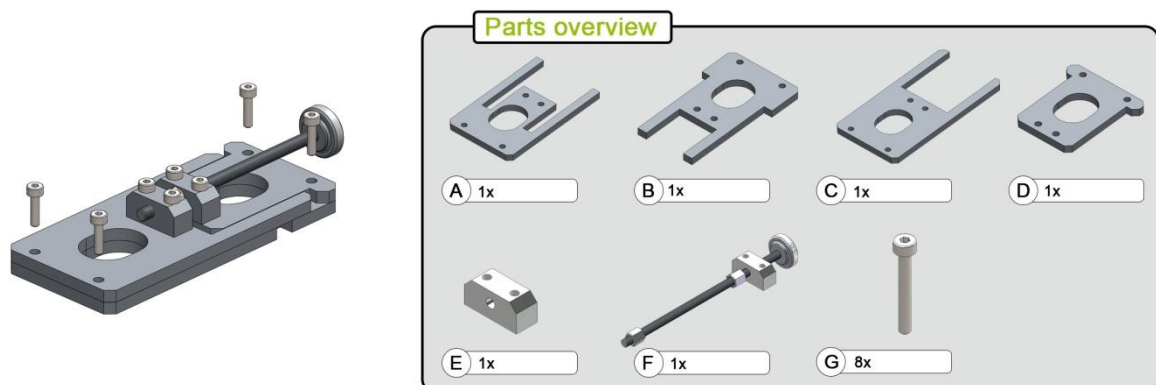

Figure 3: Parts overview of the PST-02.

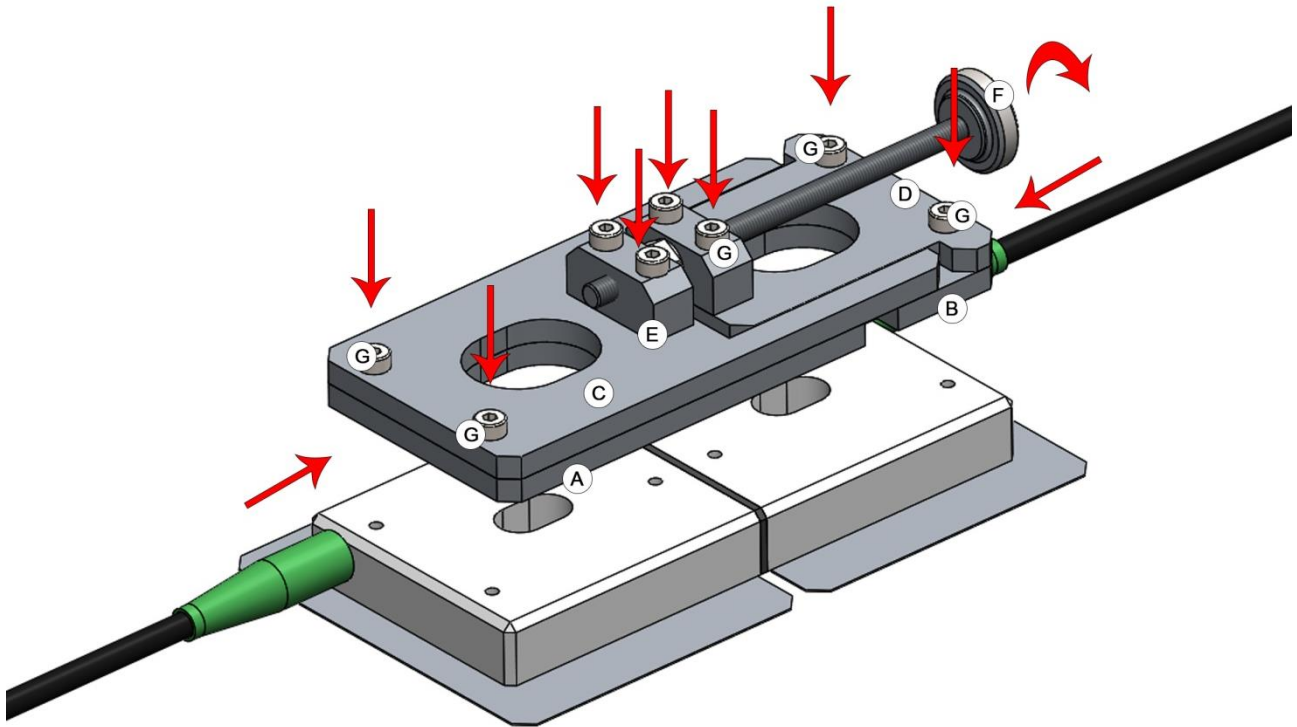

Figure 4: Assembling/Disassembling of the PST-02.

(3) Surface preparation for spot welding

Regardless of the installation method, it is advisable and in some cases even necessary to properly treat the surface of SWS-02 and the surface to which the sensor should be applied. This process includes mechanical cleaning of the surface using abrasive materials and removing any paint, rust, debris or similar imperfection from the surface.

Chemical treatment of the surface is advised 20min before the installation to avoid of creation of oxide layers on the mechanical treated surface.

Recommended cleaning solvents (not included inside the packaging):

- ▲ Loctite 7061
- ▲ Loctite 7063

(4) Spot welding of the sensor to the surface

Primary and recommended installation method for SWS-02 is spot-welding. The SWS-02 is surrounded by a 0.2mm metal sheet (base) allowing to spot-weld the sensor to the monitored structure. The base is made from a 0.2mm thick SS304 material and allows the usage of common spot-welding tools.

The necessary spot welding area of the sensor is shown in Figure 5 in green color. Follow the number order of spot welds as shown in Figure 5. One side can typically contain 10-12 spot welds as a minimum, so around 20-24 spot welds for both green areas together.

Additional spot-welds are recommended in red areas to ensure the sensor is securely mated over its entire length with measured object. You can apply 2-3 spot welds per red section, so additional 8-12 spot welds for all red areas together.

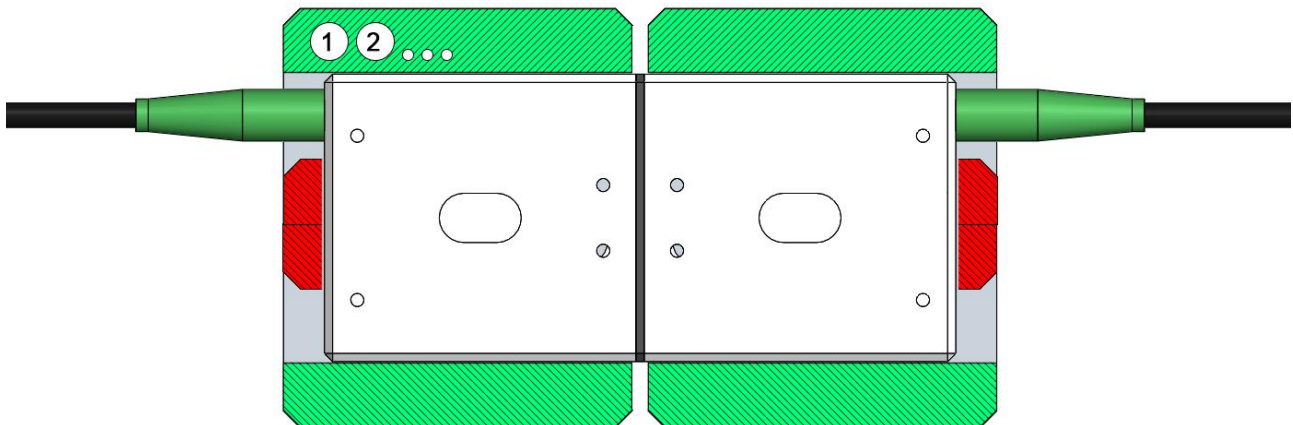

Figure 5: Recommended area of spot-weld.

(5) Removing PST-02 from the sensor

Dismount the PST-02 from the SWS-02 sensor as shown in Figure 4 – follow the reversed alphabetical order of all parts listed in “Parts overview” (Figure 3). All tools are included inside the PST-02 package.

After installation, it is recommended to verify the actual WL of the sensor with the interrogator. Small wavelength shifts that can occur during spot welding and PST-02 removal processes shouldn't exceed $\pm 50\text{pm}$.

Other possible installation methods

While the spot welding is the recommended installation method, other methods can be applied to secure the sensor on the surface of the measured object.

Mechanical installation (screwing)

Mechanical installation is based on using two standard M6 metric screws (one at each side). These screws are not supplied with the sensor. This method could be applicable i.e. to concrete, walls or even metal structures if spot welding is not allowed.

The anchoring distance is 39 +/- 4mm. This has to be respected during drilling the holes.

Follow the chapters (1) and (2) of this document to have the sensor ready and pre-strained before screwing it to the surface. Screws are then fastened on both sides of the SWS-02 sensor. ¹⁾

Then the PST-02 can be removed as described in the chapter (5) of this document.

After the installation, it is recommended to verify the actual WL of the sensor with the interrogator. Small wavelength shifts that can occur during screwing and PST-02 removal processes shouldn't exceed $\pm 150\text{pm}$.

¹⁾ Suitable thread adhesive or secure washers can always improve the stability of this installation method.

Chemical installation (glue bonding)

Chemical installation is based on using an adhesive that bonds the sensor with the measured surface. The glue is not supplied with the sensor.

The selection of the right glue highly depends on the material of the surface and environmental conditions. Special curing procedures such as elevated temperature, pressure or air humidity can be required by using such adhesives.

Follow the chapters (1) and (2) of this document to have the sensor ready and pre-strained before bonding it to the surface. The glue can only be applied to the metal areas of the SWS-02 and avoid the bonding of the non-metal areas.

After curing the adhesive the PST-02 can be removed as described in the chapter (5) of this document. It is then recommended to verify the actual WL of the sensor with the interrogator. Small wavelength shifts that can occur during bonding and PST-02 removal processes shouldn't exceed $\pm 150\text{pm}$.

For more information contact our sales team at sales@sylex.sk

* Specifications are subject to change without notice