

Product dimensions:

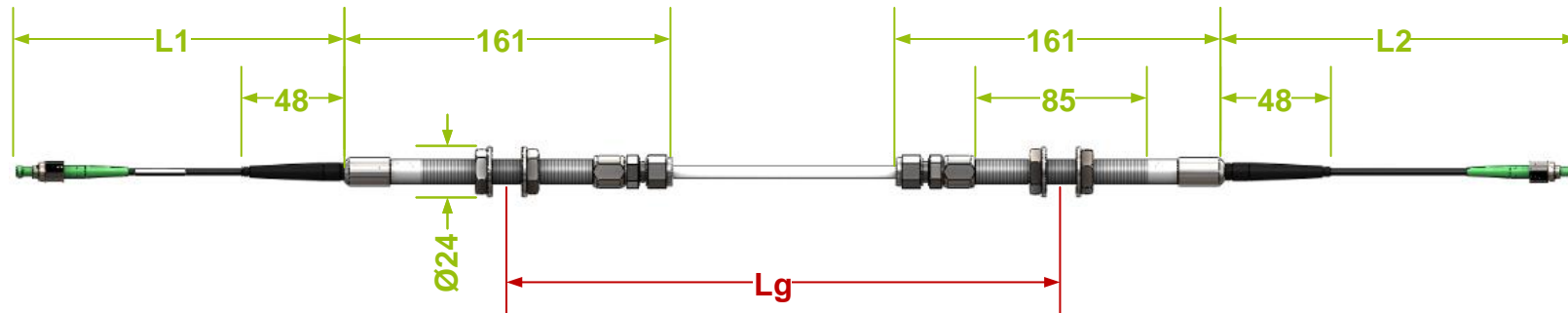

3D view

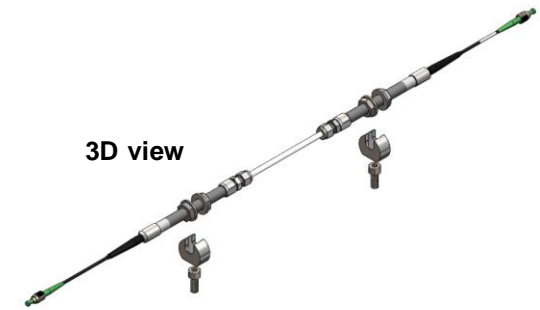

Optional accessories:

- Mounting brackets
MBS-01

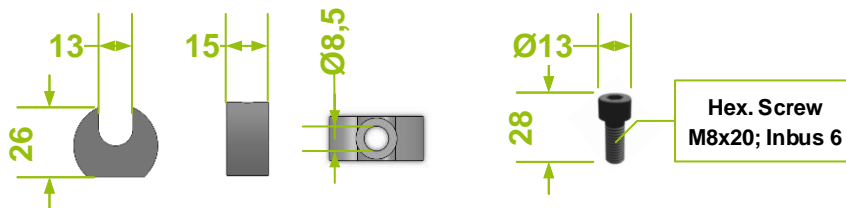

- LCP-03 Longer dyneema cable pigtail with 1x FC/APC

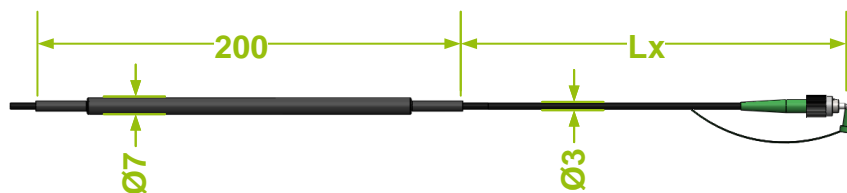

Parameter	Length	Tolerance
L1	1000 mm (standard)	± 50 mm
L2	1000 mm (standard)	± 50 mm
Lg	Optional: custom-defined gauge length	± 10 mm
Lx	Optional: custom-defined length	$\pm xx$ mm



ALL DIMENSIONS IN MM (UNLESS SPECIFIED)

DRAWN DATE : 6.12.2016

TITLE

VERSION : 01

SC-01 Strain Cable Sensor

REVISION : 01

SHEET 1 OF 1

SCALE NONE

THIS DRAWING CONTAINS INFORMATION THAT IS PROPERTY OF SYLEX s.r.l. AND SHOULD NOT BE USED WITHOUT WRITTEN PERMISSION